BATTERY INFORMATION

All stand-alone and utility interface PV systems require battery storage. Photovoltaic modules charge the batteries during daylight hours and the batteries supply the power as its needed, often at night and during cloudy weather. Utility intertie PV systems supply power directly to the utility grid: no battery storage is needed, however some inverters now incorporate features which make battery use an option.

The two most common types of rechargeable batteries in use are lead-acid and alkaline. Lead acid batteries have plates made of lead, mixed with other materials, submerged in a sulfuric acid solution.

Alkaline batteries can be either nickel-cadmium or nickel-iron batteries. They have plates made of nickel submerged in a solution of potassium hydroxide. We do not list these battery types in this catalogue because of their very high cost. But because these have up to five times the usable life of lead acid batteries, we can supply the nickel cadmium type if requested. Nickel iron batteries require higher peak voltages to become properly charged than photovoltaic modules will produce, therefore we do not sell this battery type.

Battery Size

The size of battery bank you'll need will depend on the storage capacity required, the maximum discharge rate, the maximum charge rate, and the minimum temperature at which the battery will be used. When designing a power system, all of these factors are looked at and the one requiring the largest capacity will dictate battery size.

Temperature has a significant effect on how well lead-acid batteries will perform. At 40° F a battery in good condition will have 75% of its rated capacity, and at 0° F the capacity drops to 50%.

The storage capacity of a battery, the amount of electrical energy it can hold, is usually expressed in ampere hours. If one amp is used for 100 hours, then 100 amp-hours have been used, like wise if 100 amps is used for one hour. A battery in a PV power system should have sufficient amp hour capacity to supply needed power during the longest expected period of cloudy weather. A lead acid battery should be sized at **least** 20% larger than this amount, but a ni-cad battery can be sized to exactly this amount. If there is a source of backup power, such as a stand-by generator with a battery charger, the battery bank does not have to be sized for worst-case weather conditions, but still be sufficient for three days with a 50% discharge.

Lead-Acid Batteries

Lead-acid batteries are the most common in PV systems because their initial cost is much lower and because they are readily available nearly anywhere in the world. There are many different sizes and designs of this battery type, but the most important designation is whether they are **deep cycle** batteries or shallow cycle batteries.

Shallow cycle batteries, like the type used as starting batteries in automobiles, machinery and 'Cat' batteries, are designed to supply a large amount of power (current) in a short time and stand mild overcharging without losing electrolyte. Unfortunately, none of these can tolerate being deeply discharged. If they are repeatedly discharged more than 20%, their life will be very short. These batteries are **not** a good choice for a PV system.

Deep cycle batteries are designed to be repeatedly discharged by as much as 80% of their capacity so they are a good choice for PV power systems. Even though they are designed to withstand deep cycling, these batteries will have a longer life if the cycles are not below 50%. All lead-acid batteries will fail prematurely if they are not recharged completely after each cycle. Letting a lead-acid battery stay in a discharged condition for many days at a time will cause sulfation of the positive plates and a permanent loss of capacity.

Sealed deep-cycle batteries are maintenance free. They never need additions of water or an equalizing charge. They cannot freeze or spill, so they can be mounted in any position. But, they do not give as good of service, nor do they last as long as wet plate, unsealed, liquid electrolyte battery types. Sealed battery types require **very accurate** regulation to prevent overcharge and over discharge. Either condition will drastically shorten their lives. We recommend sealed batteries only for remote, unattended power systems.

Caring For Lead-Acid Batteries

Always use extreme caution when handling batteries and electrolyte. Wear rubber gloves, aprons, goggles and old clothes. "Battery Acid" will burn skin and eyes and destroy cotton and wool clothing.

The quickest way to ruin lead-acid batteries is to discharge them deeply and let them stand "dead" for an extended period of time. When they discharge, there is a chemical change in the positive plates of the battery. They change from lead oxide when charged to lead sulfate when discharged. If they remain in the lead sulfate state for a few days, some part of the plates do not return to lead oxide when the battery is recharged. If the battery remains discharged longer, a greater amount of the positive plates will remain lead sulfate. The parts that become "sulfated" no longer store energy. **Batteries that are deeply discharged and then charged only partially on a regular basis can fail in less than one year.**

Check the battery's state-of-charge on a regular basis, either electronically or with a hydrometer, to make sure they are being full charged. Use a good quality hydrometer to check the specific gravity in each battery cell at least once each month. If the battery is deeply discharged and then recharged quickly, specific gravity readings will be lower at the top of the cell than at the bottom, as the electrolyte didn't become thoroughly mixed as it would with slower charging. Do not add water to a discharged battery, as it will be absorbed into the plates. When it is recharged the electrolyte will be pushed out of the plates and overflow out the top of the battery and make a mess.

Keep the tops of batteries clean, and remove and clean all battery and cables terminals at least once each year. Never do this when the battery is being charged or discharged. A spark can cause a hydrogen explosion inside the battery and ruin a cell, and/or you.

It is a good idea to do an equalizing charge to the batteries when any cell(s) show a variation of 0.05 specific gravity difference from each other. An equalizing charge is a controlled overcharge to the battery, which is started after the battery shows a full charge either electronically or by taking specific gravity readings. We suggest equalizing a battery every 3 months.

With proper care, lead-acid batteries will have a long service life and work well in most any power system.

Poor treatment will have the opposite results, and you'll be replacing batteries for reasons which are easily preventable.

BATTERY INFORMATION

Battery State of Charge

Battery-state-of-charge (SOC) can be measured by voltage or by specific gravity. Some care and knowledge is required to interpret this using either method. Battery voltage will vary for the same SOC depending on whether the battery is being charged or discharged, and what the current (energy) flow is in relation to the size of the battery. The chart below gives you an idea of SOC for various battery conditions in flooded cell lead-acid batteries. Voltage will vary with temperature. While charging, a lower temperature will increase battery voltage. Voltage is 0.9 volts higher on a 12 volt battery at 32° F than at 70° F. While discharging, a higher temperature will increase battery voltage. There is little temperature effect while a battery is standing. This information is courtesy of Ralph Heisy, Bogart Engineering makers of the Trimetric battery/energy meter.

A good quality temperature compensated float-tube hydrometer, like item #51-870 on page 51, is the most accurate device for measuring specific gravity in a battery to find its true state-of-charge if you measure the electrolyte from near the battery plates. Unfortunately, you can only measure the electrolyte at the top of the battery.

When a battery is being charged or discharged, a chemical reaction takes place at the border between the surface of the lead plates and the electrolyte surrounding them. During charging, the electrolyte changes from water to sulfuric acid, and becomes stronger as energy enters the battery. As the acid becomes stronger the specific gravity (or weight of the electrolyte) will rise. It takes several hours for the electrolyte to mix thoroughly inside all of the cells in a battery so that you can get an accurate reading at the top of the battery. Always try to take readings after a long period of no charge or discharge. A battery that has just become fully charged or is still under charge will have hydrogen and oxygen gas bubbles in the electrolyte and will result in a lower specific gravity reading than if the battery has been at rest for awhile. See chart below.

TABLE I. State of charge as related to specific gravity and open circuit voltage

Percentage of Charge	Specific Gravity Corrected to 80° F	Open-Circuit Voltage				
		6V	12V	24V	36V	48V
100	1.277	6.37	12.73	25.46	38.20	50.93
90	1.258	6.31	12.62	25.24	37.85	50.47
80	1.238	6.25	12.50	25.00	37.49	49.99
70	1.217	6.19	12.37	24.74	37.12	49.49
60	1.195	6.12	12.24	24.48	36.72	48.96
50	1.172	6.05	12.10	24.20	36.31	48.41
40	1.148	5.98	11.96	23.92	35.87	47.83
30	1.124	5.91	11.81	23.63	35.44	47.26
20	1.098	5.83	11.66	23.32	34.97	46.63
10	1.073	5.75	11.51	23.02	34.52	46.03

BATTERY INFORMATION

Battery Interconnection Wiring

Lead acid batteries are commonly available in 2, 6 and 12 volt configurations. They can be wired in series to increase voltage or in parallel to increase amp-hour capacity. A combination of series and parallel connections may be used to achieve proper capacity and voltage in larger systems. Battery cables bolted to lead posts should be tightened to approximately 10 foot-pounds with a wrench. It is a good idea to clean battery posts and cable terminals at least once each year and retighten the bolts to the proper torque.

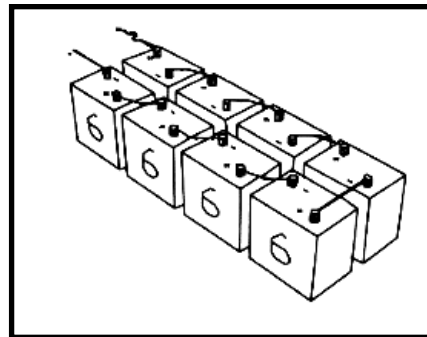
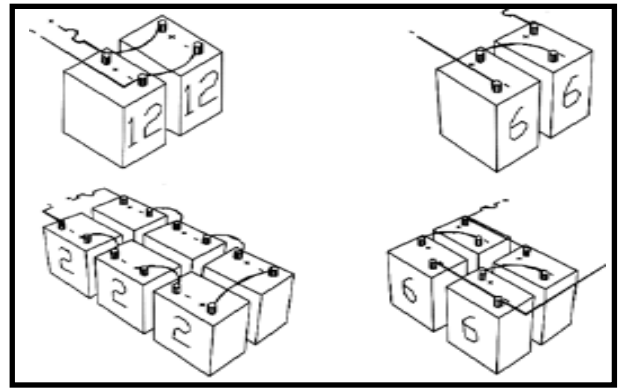
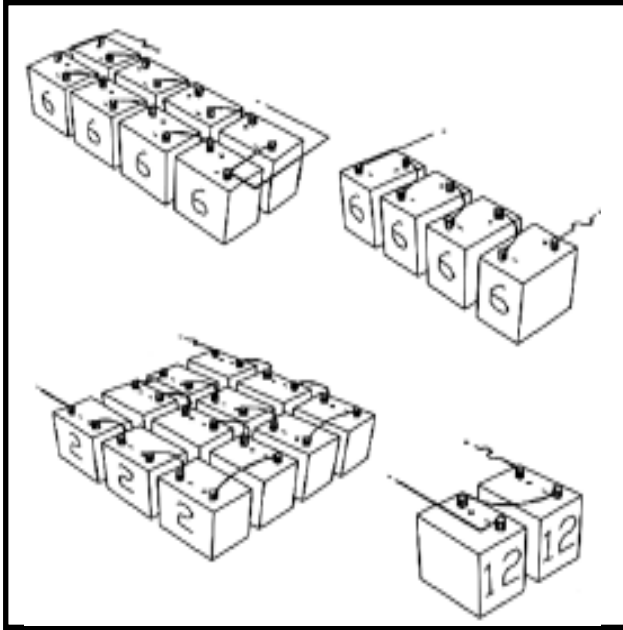

Battery Voltage @ 77 degree F (25 C)

Battery near full charge while charging
 Battery near full discharge while charging
 Battery fully charged with light load
 Battery fully charged with heavy load
 No charge or discharge for 6 hrs - 100% full
 No charge or discharge for 6 hrs - 80% full
 No charge or discharge for 6 hrs - 40% full
 No charge or discharge for 6 hrs - 20% full
 No charge or discharge for 6 hrs - fully discharged
 Battery near full discharge while discharging

	12 Volt	Battery Condition 24 Volt
Battery near full charge while charging	14.4 to 15.0	28.8 to 30.0
Battery near full discharge while charging	12.3 to 13.2	24.6 to 26.4
Battery fully charged with light load	12.4 to 12.7	24.8 to 26.4
Battery fully charged with heavy load	11.5 to 12.5	23.0 to 25.0
No charge or discharge for 6 hrs - 100% full	12.8	25.6
No charge or discharge for 6 hrs - 80% full	12.5	25.0
No charge or discharge for 6 hrs - 40% full	11.9	23.8
No charge or discharge for 6 hrs - 20% full	11.6	23.2
No charge or discharge for 6 hrs - fully discharged	11.4	22.8
Battery near full discharge while discharging	10.2 to 11.2	20.4 to 22.4

BATTERY SIZING WORKSHEET

Use this worksheet to determine the total size and capacity, in ampere hours, of the battery or battery bank required for your power system.

Battery size is measured in AMP-HOURS. This is a measure of battery capacity, or the total amount of electrical energy it will hold when fully charged.

Battery voltage is determined by the number of "cells" connected together in series. All individual lead-acid battery cells have a nominal output of 2 volts. Actual cell voltage will vary from about 1.7 volts when discharged to 2.4volts when fully charged.

12 volt lead-acid batteries are made with 6 series connected 2 volt cells. 6 volt batteries are made with 3 series connected 2 volt cells. The operating voltage of a battery is determined by connecting any number of 2 volt cells in series to reach the desired end voltage

If the battery has a large capacity, it will be made with 2 volt cells, or multiples of 2 volt cells, inside a single case. Small capacity batteries are made with all of the 2 volt cells inside a single case.

Connecting batteries together in parallel increases the total amp-hour capacity, but the operating voltage remains constant.

We provide a complete and comprehensive set of battery maintenance and care instructions with all batteries we sell.

Use this worksheet to determine the size of battery(s) required for your system.

1. Solar array amp hours per day required from Systems Load Worksheet, on Page 8, line 9. _____
2. Number of continuous cloudy days expected in your area. (at least 3) _____
3. Multiply line 1 by line 2. _____
4. Divide line 3 by 0.5 to maintain a 50% reserve for extended battery life. If no special condition, skip to line 10. _____

Special Condition #1: Heavy electrical load

5. Maximum amperage that will be drawn by the loads for a period of 10 minutes or more. _____
6. Discharge rate of battery. If unknown, check with battery supplier. _____
7. Multiply line 5 by line 6. _____

Special Condition #2: High Charge Current.

8. Maximum output amperage of the PV array or other charging source. _____
9. Multiply line 8 by 10.0 hours. _____
10. Amp hours from line 4, 7 or 9, whichever is largest. _____
11. If you are using a lead acid battery, select the multiplier below which corresponds to the battery's wintertime average ambient temperature. _____

Battery Temperature	Multiplier
80°F/26.7°C	1.00
70°F/21.2°C	1.04
60°F/15.6°C	1.11
50°F/10.0°C	1.19
40°F/4.4°C	1.30
30°F/1.1°C	1.40
20°F/-6.7°C	1.59

12. Multiply line 11 by line 10. This is your optimum battery size. _____
13. Amp-hours of battery chosen:
Yuasa (model & amp hours), (85T-19=960 amp hour)
Crown (GC 225=225amphour) etc. from page 47 & 48. _____
14. Divide line 12 by line 13. This is the total number of batteries in parallel required. _____
15. Round off to the next highest whole number. _____

ROLLS/SURRETTE DEEP-CYCLE BATTERIES

These are the new generation, dual container, deep cycle Rolls batteries from Surrette. They are high-capacity batteries with a heavy-duty plate grid to resist positive plate breakdown. The plates are double-insulated with glass mat and a polyethylene envelope, eliminating the possibility of separator misalignment, cracked separators, treeing or shorting at the bottoms or sides. Rolls batteries are rated at 3200 cycles at 50% depth of discharge and over 5000 cycles at 20%. Each 2-volt cell is built into its own lightweight container made of durable polypropylene with the cover heat bonded to the container, thus acid leakage is eliminated. The cells are then assembled into a tough, lightweight polyethylene outer container with a removable lid. Even if the outer case is broken the battery remains operable and spill-free. The individual cells of the CS and KS series are bolted together allowing the battery to be disassembled. The cells can be independently removed.



This facilitates easy on-site installation, disassembly, assembly, or replacements of individual cells without special skills or tools. All Surrette CS & KS deep cycle solar batteries come with a 10-year warranty, 3-year full warranty and 7-year prorated warranty.

These batteries are usually not stocked, take 5-6 weeks to arrive and are shipped from Edmonton. Ask us for a freight quote.

Item #	Surrette Model	Battery voltage	Capacity @ 20hr rate	Capacity@ 100hr rate	L in "	W in "	H in "	Weight lbs	Price
40-500	2-KS-33PS	2	1766Ah	2491Ah	15.5	8.3	24.8	208	\$ 988
40-501	2-YS-31PS	2	2430Ah	3435Ah	15.5	9	31.6	285	\$1,364
40-505	4-CS-17PS	4	546Ah	770Ah	14.4	8.3	18.3	128	\$ 828
40-506	4-KS-21PS	4	1104Ah	1557Ah	15.8	9.4	24.8	267	\$1,259
40-507	4-KS-25PS	4	1350Ah	1900Ah	15.8	10.6	24.8	315	\$1,572
40-510	6-CS-17PS	6	546Ah	770Ah	22	8.3	18.3	221	\$1,043
40-511	6-CS-21PS	6	683Ah	963Ah	22	9.8	18.3	271	\$1,268
40-512	6-CS-25PS	6	820Ah	1156Ah	22	11.3	18.3	318	\$1,499
40-515	8-CS-17PS	8	546Ah	770Ah	28.3	8.3	18.3	294	\$ ask
40-516	8-CS-25PS	8	820Ah	1156Ah	28.3	11.3	18.3	424	\$ ask
40-518	12-CS-11PS	12	375Ah	503AH	22	11.3	18.3	272	\$ ask

HUP SOLAR-ONE DEEP-CYCLE BATTERIES

The Solar-One battery with HuP Technology is optimized for renewable energy systems. It has a slightly enlarged epoxy-coated steel case that allows cell removal and easier installation without a forklift or crane. Solar-One batteries are designed with 0.310" thick positive plates and a patented technology that allows them to be warranted for 2100 cycles to 80% DOD. The 10 year-warranty, 7-year free replacement and 3 years prorated is the best in the RE industry. Each Solar-One is made up of six 2-volt cells and comes with stainless steel hardware, lead-plated copper buss bars, a cell lifting strap and an operator/installation manual. Order two for 24-volt systems or four for 48-volt systems. Many sizes are in stock and available for immediate shipment. Other sizes are made to order; please allow up to 8 weeks for delivery. **Ask for a freight quote.**



Item #	Cell Type 12 volt	Capacity @ 20hr rate	Dimensions L"xW"x25"H	Weight lbs	Price
40-570	SO-6-85-17	845Ah	40 x 7.75	742	\$4,771
40-571	SO-6-85-19	950Ah	40 x 8.25	808	\$4,982
40-572	SO-6-85-21	1055Ah	40 x 8.75	880	\$5,338
40-573	SO-6-85-23	1160Ah	40 x 9.0	959	\$5,926
40-574	SO-6-85-25	1270Ah	40 x 10.25	1036	\$6,141
40-575	SO-6-85-27	1375Ah	40 x 11.25	1102	\$6,638
40-576	SO-6-85-31	1585Ah	40 x 12.75	1252	\$7,769
40-577	SO-6-85-33	1690Ah	40 x 13.5	1336	\$7,955
40-578	SO-6-100-33	1990Ah	40 x 13.5 x 28	1550	\$9,366
40-579	SO-6-125-33	2490Ah	40 x 13.5 x 33	1698	\$10,847

COMMERCIAL LEAD ACID BATTERIES

These deep cycle battery types have the lowest cost per amp hour. We recommend these for small to medium sized home power systems, remote cabins and cottages. They will generally last from 3 to 7 years, and even longer if diligently maintained and properly cycled. Note: We can have these batteries drop shipped in Canada for a savings in freight, contact us for the nearest shipping point to your location.



US-2200 - 232 Amp Hour 6 Volt Battery

The US-2200 6 volt battery is popular for small remote home power systems and solar water pumping applications, because of its high quality, relatively light weight and reasonable price. Use two in series for 12 volts and four in series for 24 volts. Life expectancy is 3 to 5 years. Weight is 65 pounds and dimensions are 10 x 7" x 11 high. FOB Edmonton, AB.

40-230 6 Volt 220 Amp Hour Battery

\$219

US-L16 Battery, 6V 385AH

A large and robust electric vehicle and traction battery. The lead plates are twice as thick so it can withstand more abuse, be deep cycled more times and last longer. Flag-style 'T' terminals allow connecting large size cables. Life expectancy is 5 to 8 years. Two year warranty. Dimensions are 12" x 7" x 16" high and it weighs 120 pounds. Capacity is 375 amp-hours (6V) and 1050 amp-hours (2V) at a 20 hour discharge rate. FOB Edmonton, AB

40-350 385 AH Battery 6V

\$449



Surrette S-4000Series batteries

These S-4000 series L16 sized batteries are rated at 800 cycles to 80% depth of discharge and 1500 cycles to 50% DOD. Life expectancy is 10 years. Seven years prorated warranty. Dimensions are 12" x 7" x 16" high and weight 120 pounds. FOB Edmonton, AB

40-530 S-480, 375AH 6V Surrette Solar Battery \$445

40-531 S-550, 428AH 6V Surrette Solar Battery \$489

40-533 S-1450, 1124AH 2V Surrette Solar Battery \$494

AGM Sealed Batteries

The Discover EV-Series is a valve regulated, absorbent glass matt, lead acid battery designed specifically for deep cycle applications. This makes an excellent battery for alternative energy use. It also requires almost no maintenance and since it does not gas, the battery bank needs no venting. The VRS12-100C also has the ability to operate effectively in broad temperature extremes (-40 to 60C) making it a good battery for use in cold locations. Each battery is fitted with "L" type terminals that have clearance holes for 1/4" bolts. It can be used in multiple orientations (upside down is not recommended).



Catalogue Number	Volts	Amp Hours	Weight lbs	Dimensions L x W x H	Price
40-430	6	200	67	12"x6.6"x8.9"	\$ 374
40-431	6	225	77	10.2"x7.1"x10.8"	\$ 399
40-432	6	390	123	11.6"x7.1"x16.8"	\$ 689
40-440	12	55	36	9.1"x5.4"x8.8"	\$ 299
40-441	12	85	56	10.7"x6.8"x6.9"	\$ 298
40-442	12	100	65	12.7"x6.8"x8.9"	\$ 354
40-443	12	115	74	13.1"x7.1"x9.3"	\$ 409
40-451	2	1170	123	11.6"x7.1"x16.8"	\$ 772
40-452	2	550	73	9.5"x6.7"x14.4"	\$ 487
40-453	2	880	126	16.1"x6.9"x14.4"	\$ 755
40-454	2	1100	147	19.0"x6.9"x14.4"	\$ 923
40-455	2	1650	229	15.7"x13.8"x16.8"	\$1,414

BATTERY ACCESSORIES

Heavy Duty Battery Interconnects

To connect individual batteries together. Total load divides equally among battery strings in parallel so 2 gauge may be adequate within each string. Heavier 2/0 is for connections between ends of series strings. Heaviest 4/0 Shunt /Inverter Cable connects battery negative to meter shunt, or for longer cable between shelves or rows of batteries.

50-950	Battery Interconnect	1ga	16" black	\$10.50
50-951	Battery Interconnect	2/0ga	8" black	\$16.50
50-952	Battery Interconnect	2/0ga	8" red	\$16.50
50-953	Battery Interconnect	2/0ga	13" black	\$19.50
50-954	Battery Interconnect	2/0ga	13" red	\$19.50
50-955	Battery interconnect	2/0ga	16" black	\$22.50
50-956	Battery Interconnect	2/0ga	16" red	\$22.50
50-957	Battery Interconnect	2/0ga	24" black	\$29.75
50-958	Battery Interconnect	2/0ga	24" red	\$29.75



Dual Battery Relay

This relay is designed to isolate a second battery in a vehicle. The contact terminals are connected between the positive terminal of the starting battery and the positive terminal of the second battery. The negative terminals of both batteries attach to the vehicle chassis. One of the coil terminals is connected to the chassis ground and the other coil is connected to the ignition switch or fuse box. When the vehicle is running, both batteries are connected together in parallel and both are being charged by the alternator. When the ignition switch is off, the contacts are open, disconnecting the second battery from the vehicle electrical system.

52-440	Dual Battery Relay	\$45
--------	--------------------	------



Dual Battery Selector Switch

This high current switch is designed for battery switching in RVs and boats. It permits manual selection between one of two batteries or the connection of both batteries in parallel. The "off" position also acts as a battery disconnect. Many people are using these to choose between two banks of nickel cadmium batteries or between a main battery and a back-up battery in the same system.

This switch surface mounts with a slot for wires to enter from the bottom. Wires connect to 3/8" brass bolts. Capacity is 250 amps continuous and 360 amps intermittent. For use on 6, 12, 24 or 32 volt systems. Dimensions are 5-1/4" diameter X 2-5/8" deep. Marine UL listed.

52-170	Battery Selector Switch	\$65
--------	-------------------------	------



Battery Hydrometers

The most accurate way to measure the state of charge of a wet cell lead acid battery is by testing its electrolyte specific gravity. A proper test cannot be made if water has recently been added to a battery cell. We caution, make sure your hydrometer is clean before testing cells to avoid contamination of the electrolyte. Be aware, battery electrolyte is corrosive! If you get acid on cotton clothing you get holes.

This quality hydrometer reads actual specific gravity for an accurate measurement of battery state of charge. Built-in thermometer for temperature correction. Variation of .05 or greater specific gravity between cells indicates a need for equalization charging or the presence of a weak cell.

51-870	Float Tube Hydrometer	\$ 9.50
--------	-----------------------	---------



BATTERY CHARGERS



Iota Battery Chargers

The Iota DLS Series of Battery Chargers offers advanced switch-mode technology for clean DC output. The clean DC output operates radios and TV's without causing interference. Batteries are charged quickly and efficiently without ever overcharging. The chargers are virtually service free even in harsh conditions. The DLS converter/power supply can be used with or without a battery. When used as a converter/power supply, the DLS will only supply what is required of the load. When not in use it is essentially off, reducing electricity usage. IQ Smart Controller allows the DLS charger to operate as a 3 stage smart charger. The user receives the benefits of Bulk, Absorption & Float Stage charging.



Catalogue Number	Model Number	Amp	Volt	Price
51-102	DLS-30	30	12	\$257
51-103	DLS-45	45	12	\$296
51-104	DLS-55	55	12	\$312
51-105	DLS-75	75	12	\$499
51-106	DLS-90	90	12	\$649
51-107	DLS27/25	25	24	\$445
51-108	DLS 27/40	40	24	\$579
51-109	IQ-4-12/24	3 Stage Smart Controller		\$ 45
51-110	IQ-4-Parallel			\$ 55
51-111	DLS-54/15	15	48	\$624
51-112	DLS-27/15	15	24	\$369

TRANSFORMERS

120/240 VAC Autotransformers

These AC step-up and step-down transformers are greater than 98% efficient and cause less than 0.2% idle loss at no load. They are nearly silent operating. Use an autotransformer as step-down to connect the 240 volt output of a generator to the 120 volt input on an inverter. This allows full output power of a 240 volt generator to be used for battery charging.

Use an autotransformer as a step-up to operate 240 volt pumps and appliances and motors from the 120 volt output of an inverter. Autotransformers are in NEMA 1 enclosures with knockouts for conduit.



Step-up / Step-down Autotransformers

	Watts	Dimensions Inches	Weight Lbs	Catalog No.	Price
Toroid 2.5kw	2500	8 x 8 x 4	18	31-102	\$ 698
Toroid 4kw	4000	10 x 10 x 4	27	31-104	\$ 829
Toroid 8kw	8000	12 x 12 x 4	44	31-107	\$ n/a

OutBack PSX-240 6000 16 x 12 x 11 41 31-150 \$1,175

for integrating into FW500 or FW1000 power centers:

OutBack FW-X240 4000 10 x 10 x 11 32 31-151 \$ 975

